

OLS-S

OPTICAL LAY-UP STATION
(SINGLE)

RIGID



85 HOFFMAN LANE, SUITE Q
ISLANDIA, NY 11749 USA
+1 (631) 851-0102
DISTECHNOLOGY.COM

Member of the

DATAALIGN™
SERIES OF EQUIPMENT



The Optical Lay-up Station Single (OLS-S), is a fully automated system including panel setup to loading & unloading of material. Some key features include automated weld bars and heads for different panel sizes and welding positions. This system is capable of handling a range of job sizes from small prototype runs to higher volume multi stackup production runs.

All OLS systems come standard with SmartWeld™ Induction Technology coupled with Optical Alignment. These two technologies eliminate mechanical tooling and improve process flexibility by decreasing operational cycle times and reducing operating costs while delivering better layer to layer registration than conventional pin systems.

The OLS-S Optical Alignment system is a fully automated layer positioning system which sequentially aligns and clamps multi-layer PCB's together. SmartWeld™ Induction Technology then welds the aligned multi-layer boards together, which ensures the accuracy of the registration is secured at several points on the border of the panel.

Other key features to aid with registration and accuracy are barcode scanners for mistake proofing lay-up, as well as thickness measurement for Layer and Prepreg thickness verification.

PROCESSING CAPABILITIES

- Minimum: 12" x 14"
305mm x 355mm
- Maximum: 24" x 30"
610mm x 762mm
- Easily align thin cores (1mil-25 µm)
- +/- 12 µm alignment tolerance or better
- Maximum Weld Thickness
 - 8mm
- Maximum Weld Temperature
 - 300 °C

FOOTPRINT

TOP VIEW

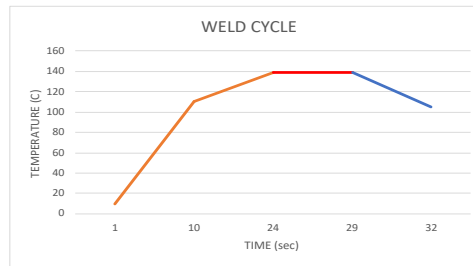
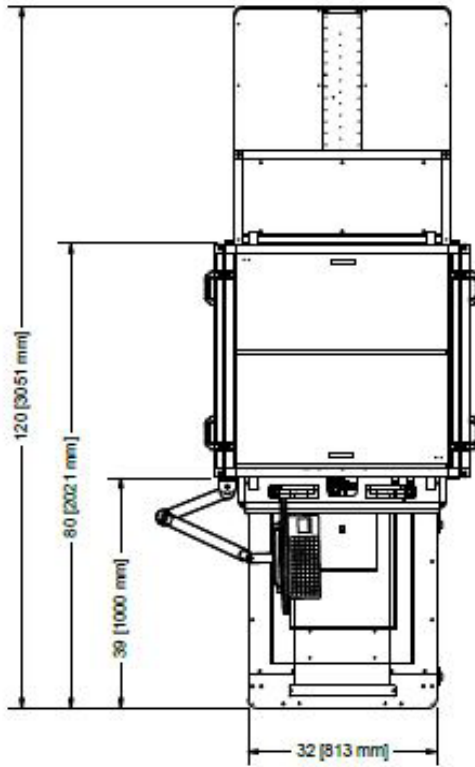

- RAMP RATE
- WELD HOLD TIME
- COOLING

FRONT VIEW

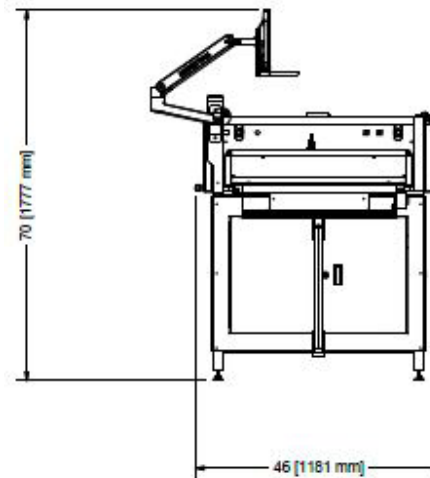

SIDE VIEW

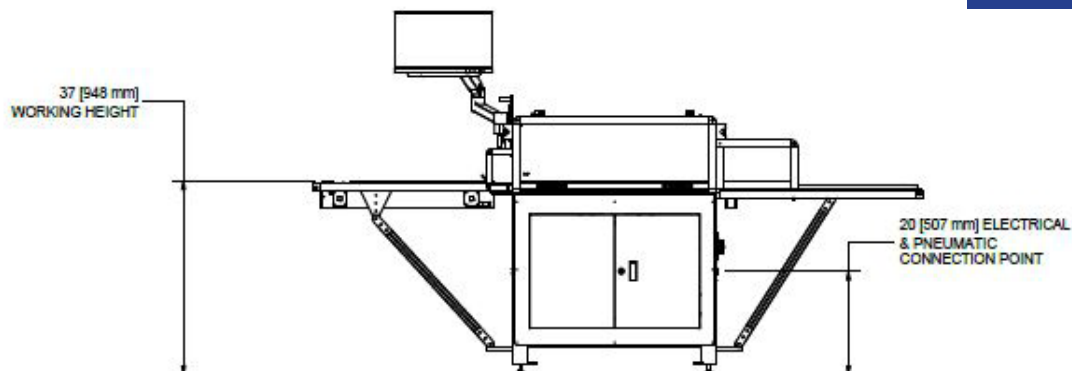

Machine Requirements

Air Requirements

- 85 psi (6 bar) 15 SCFM (425 lpm)
Air Hose: Minimum 3/8" (10mm) inside diameter

Power Requirements

- 205-240VAC 11A 3 Phase 50/60Hz
Power Cord: 4 conductor 3.3 mm, 2 gauge wire, machine grade

Visit us at:

